

BK 4... with flanges

Steam Traps

**BK 45, BK 45-U, BK 45-LT, BK 46**

**PN 40**

**DN 15, 20, 25 (½", ¾", 1")**

**Description**

When the plant is started up, the trap is fully open. Cold condensate and air are discharged. With rising temperature, the Duo (bimetallic) stainless steel plates bend and pull the stage nozzle into the closing position.

The orifice is then closed immediately below the saturation temperature. Thermodynamic processes taking place in the stage-nozzle chamber support the closing procedure.

The trap provides automatic air-venting at start-up and during operation. BK 45 and BK 46 can also be used for thermal air-venting in steam systems.

**Pressure /Temperature Ratings & End Connections**

<b>BK 45, BK 45-U, flanged PN 40, EN 1092-1</b>							
PMA (max. allowable pressure)	[bar]g	40.0	33.3	27.6	25.7	23.8	13.1
TMA (max. allowable temperature)	[°C]	20	200	300	350	400	450
Δ PMX (admissible differential pressure)	[bar]	22					

Based on EN 1092-1

<b>BK 45, BK 45-U, flanged Class 150, ASME B16.5</b>							
PMA (max. allowable pressure)	[bar]g	19.6	13.8	10.2	8.4	6.5	5.5
TMA (max. allowable temperature)	[°C]	-29/38	200	300	350	400	425
Δ PMX (admissible differential pressure)	[bar]	22					

Based on ASME B16.5, ASME B16.34

<b>BK 45, BK 45-U, flanged Class 300, ASME B16.5, butt-weld ends EN 12627, socket-weld ends EN 12760, socket-weld ends Class 3000, ASME B16.11, screwed sockets G, ISO 228-1, screwed sockets NPT, ASME B16.11</b>							
PMA (max. allowable pressure)	[bar]g	51.1	43.8	39.8	37.6	34.7	28.8
TMA (max. allowable temperature)	[°C]	-29/38	200	300	350	400	425
Δ PMX (admissible differential pressure)	[bar]	22					

Based on ASME B16.5, ASME B16.34

<b>BK 45-LT, flanged Class 150, ASME B16.5</b>							
PMA (max. allowable pressure)	[bar]g	19.6	13.8	10.2	8.4	6.5	5.5
TMA (max. allowable temperature)	[°C]	-46	200	300	350	400	425
Δ PMX (admissible differential pressure)	[bar]	22					

Based on ASME B16.5, ASME B16.34

<b>BK 45-LT, flanged Class 300, ASME B16.5, butt-weld ends EN 12627, socket-weld ends EN 12760, socket-weld ends Class 3000, ASME B16.11, screwed sockets G, ISO 228-1, screwed sockets NPT, ASME B16.11</b>							
PMA (max. allowable pressure)	[bar]g	51.1	43.8	39.8	37.6	34.7	28.8
TMA (max. allowable temperature)	[°C]	-46	200	300	350	400	425
Δ PMX (admissible differential pressure)	[bar]	22					

Based on ASME B16.5, ASME B16.34

<b>BK 46, flanged PN 40, EN 1092-1</b>							
PMA (max. allowable pressure)	[bar]g	40.0	39.0	34.2	32.3	29.9	27.6
TMA (max. allowable temperature)	[°C]	20	250	300	350	400	450
Δ PMX (admissible differential pressure)	[bar]	32					

Based on EN 1759-1

<b>BK 46, flanged Class 150, ASME B16.5</b>							
PMA (max. allowable pressure)	[bar]g	20.0	14.0	10.2	8.4	6.5	4.7
TMA (max. allowable temperature)	[°C]	-10/50	200	300	350	400	450
Δ PMX (admissible differential pressure)	[bar]	32					

Based on EN 1759-1

<b>BK 46, flanged Class 300, ASME B16.5, butt-weld ends EN 12627, socket-weld ends EN 12760, socket-weld ends Class 3000, ASME B16.11, screwed sockets G, ISO 228-1, screwed sockets NPT, ASME B16.11</b>							
PMA (zulässiger Betriebsdruck)	[bar]g	51.7	44.2	35.0	32.9	30.9	29.8
TMA (zulässige Temperatur)	[°C]	-10/50	200	300	350	400	450
Δ PMX (zulässiger Differenzdruck)	[bar]	32					

Based on EN 1759-1

## Materials

Type	BK 45, BK 45-U	
Designation	DIN / EN	ASME
Body and cover	1.0460	A105
Hexagon-head cap screws	1.7225	A193 B7
Gasket	Graphite/CrNi	
Regulator with Duo steel plates	Stainless steel	
Other internals	High-grade steels	

Type	BK 45-LT	
Designation	ASME	
Body and cover	SA350 LF2	
Hexagon-head cap screws	A193 B7	
Gasket	Graphite/CrNi	
Regulator with Duo steel plates	Stainless steel	
Other internals	High-grade steels	

Type	BK 46	
Designation	DIN / EN	ASME equivalent*
Body and cover	1.5415	A182 F1
Hexagon-head cap screws	1.7225	A193 B7
Gasket	Graphite/CrNi	
Regulator with Duo steel plates	Stainless steel	
Other internals	High grade steels	

\*) ASTM material similar to EN material. Observe different physical and chemical properties!

## Component Parts BK 45, BK 45-U, BK 45-LT BK 46

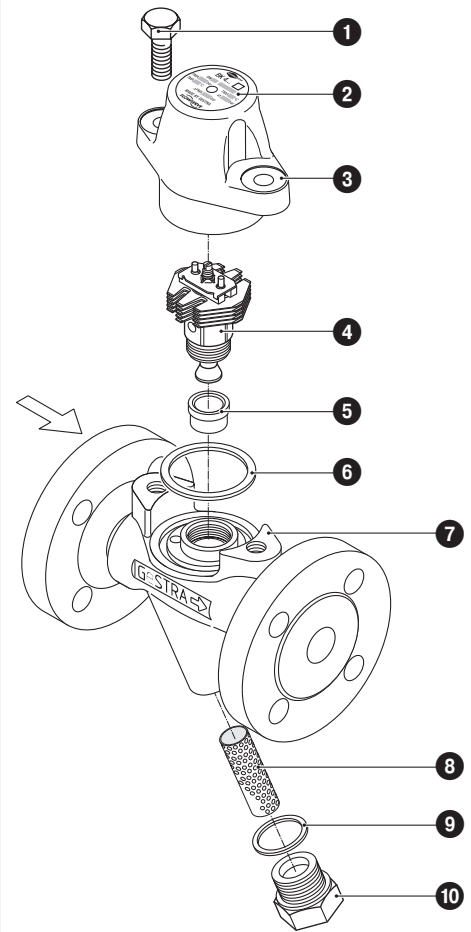

### Key

- 1 Hexagon-head screw M 10 x 25
- 2 Name plate
- 3 Cover
- 4 Thermovit regulator
- 5 Bushing (interference fitted, no spare part)
- 6 Gasket 40 x 48 x 2
- 7 Body
- 8 Strainer
- 9 Gasket A 24 x 29
- 10 Sealing plug

Spare parts list see page 3

## Dimensions

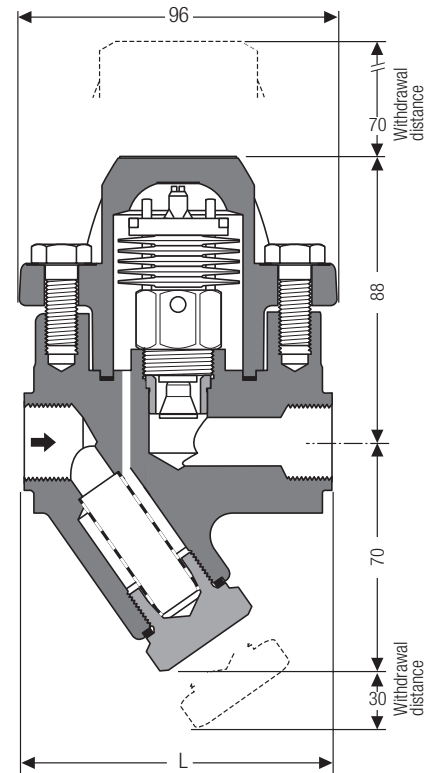
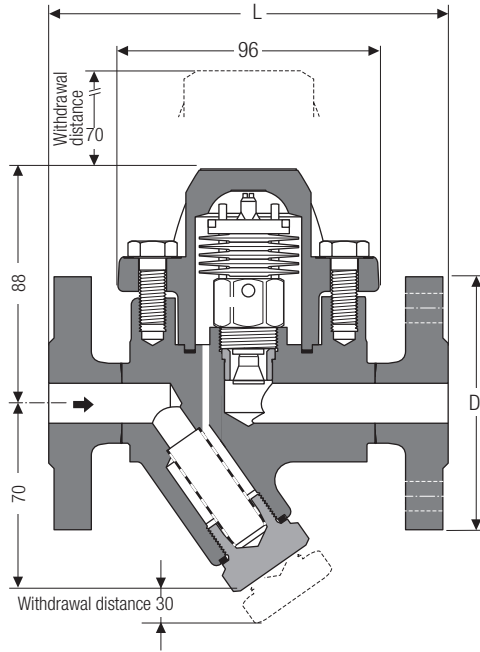

## Weights and dimensions for traps with flanged ends

Type	Flanged to	EN 1092-1 PN 40			ASME B 16.5 Class 150			ASME B 16.5 Class 300		
		15	20	25	15	20	25	15	20	25
<b>BK 45, BK 45-U, BK 45-LT, BK 46</b>	DN	1/2"	3/4"	1"	1/2"	3/4"	1"	1/2"	3/4"	1"
	D [mm]	95	105	115	88.9	98.4	107.9	95.2	117.5	123.8
	L [mm]	150	150	160	150	150	160	150	150	160
	[kg]	3.7	4.3	4.8	3.7	4.3	4.8	3.7	4.3	4.8

## Weights and dimensions for traps with butt-weld ends

Type	Butt-weld ends to	EN 12627 Edge form to ISO 9692, code number 1.3			ASME B 16.25 ASME B 36.10		
		15	20	25	15	20	25
<b>BK 45, BK 45-U, BK 45-LT, BK 46</b>	DN	1/2"	3/4"	1"	1/2"	3/4"	1"
	for pipe	21.3 x 2.0	26.9 x 2.3	33.7 x 2.6	21.3 x 2.8	26.7 x 2.9	33.4 x 3.4
	L [mm]	200	200	200	200	200	200
	[kg]	2.5	2.5	2.5	2.5	2.5	2.5

Butt-weld ends for other pipe sizes available on request.

## Weights and dimensions for traps with socket-weld ends

Type	Socket-weld ends to	DIN EN 12760, ASME B 16.11 Class 3000		
		15	20	25
<b>BK 45, BK 45-U, BK 45-LT, BK 46</b>	DN	1/2"	3/4"	1"
	L [mm]	95	95	95
	[kg]	2.2	2.1	2.0

## Weights and dimensions for traps with screwed sockets

Type	Screwed sockets to	BSP: ISO 228-1, NPT: ASME B 16.11		
		15	20	25
<b>BK 45, BK 45-U, BK 45-LT, BK 46</b>	DN	1/2"	3/4"	1"
	L [mm]	95	95	95
	[kg]	2.2	2.1	2.0

## Spare Parts

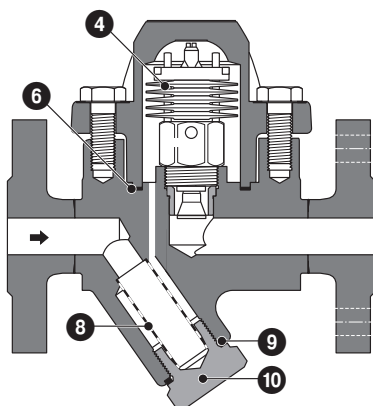

Item	Designation	Stock code BK 45, BK 45-LT	Stock code BK 45-U	Stock code BK 46
4 / 6	Thermovit regulator, gasket	375 234	375235	375464
8 9 10	Strainer set, cpl.	375 113	375 113	375113
6	Gasket*) 40 x 48 x 2, graphite	375 159	375 159	375159
9	Gasket*) A 24 x 29, stainless steel	375 162	375 162	375162

\*) Minimum purchasing quantity 50 pcs. For smaller quantities please contact your local dealer.

## Steam Traps

### BK 45, BK 45-U, BK 45-LT, BK 46 PN 40 DN 15, 20, 25 (½", ¾", 1")

#### Capacity Charts

The charts show the maximum capacities for hot and cold condensate.

##### Curve 1

Indicates the max. capacity of hot condensate that steam traps BK 45 and BK 46 with standard regulator can discharge with virtually no banking-up.

The BK 45-U (undercooling) discharges the condensate when it is approx. 30 K (degC) below saturation temperature (banking-up of condensate).

##### Curve 2

Discharge capacity for cold condensate at 20 °C.

#### Specification Text

GESTRA Steam trap, DN 15 / DN 20 / DN 25

Type: BK 45 (1.0460)

Type: BK 45-U (1.0460, 30 K undercooling)

Type: BK 45-LT (SA350 LF2)

Type: BK 46 (1.5415)

End connection: Flanged / socket-weld ends /  
butt-weld ends / screwed sockets

Nominal size: DN 15 / 20 / 25 / ½"/¾"/1"

Pressure rating: PN 40 / CL 150 / CL 300

Regulator: Standard,  $\Delta t$  approx. 15 K  
(BK 45, BK 46)  
**U** = Undercooling,  $\Delta t$  approx. 30 K  
(only BK 45-U)

#### Inspection & Certification

Documentation regarding material tests and in-house examination with test report EN10204-2.2 or inspection certificate EN10204-3.1 available at extra cost. All inspection requirements have to be stated with the enquiry or order. After supply of the equipment certification cannot be established. Charges and extent of the above mentioned test certificates as well as the different tests confirmed therein are listed in our Price List "Test and Inspection Charges for Standard Equipment". For other tests and inspections than those listed above, please consult us.

#### PED (Pressure Equipment Directive)

The equipment fulfills the requirements of the Pressure Equipment Directive PED 97/23/EC. For use with fluids of group 2. The equipment is excluded from the scope of the PED according to section 3.3 and must not bear a CE marking.

#### ATEX (Atmosphère Explosible)

The equipment does not have its own potential source of ignition and is therefore not subject to the ATEX Directive 94/9/EC. Applicable in Ex zones 0, 1, 2, 20, 21, 22 (1999/92/EC). The equipment is not Ex marked.

Supply in accordance with our general terms of business.

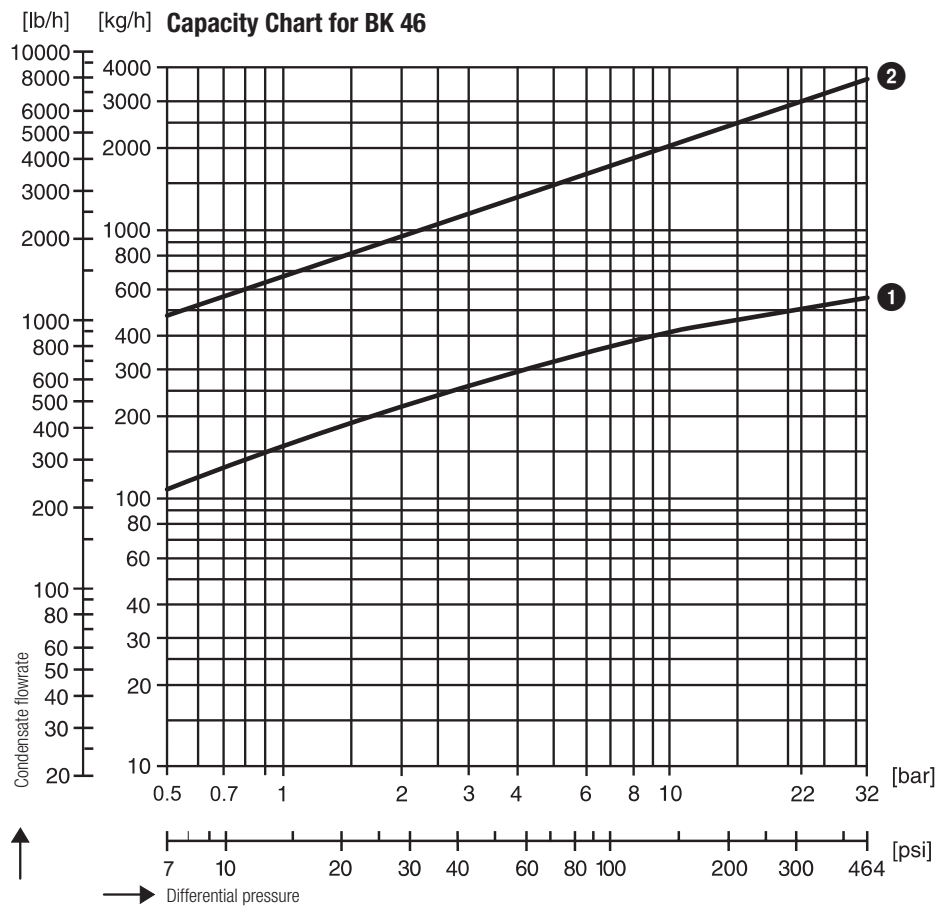
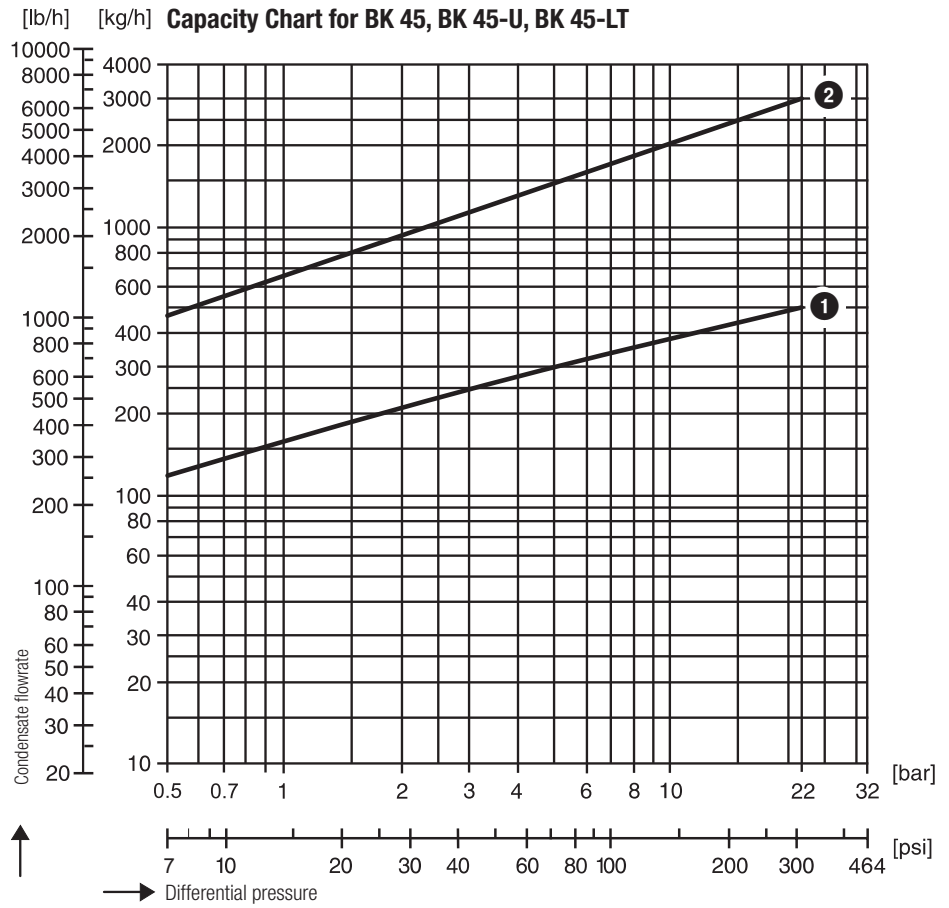

## GESTRA AG

P. O. Box 10 54 60, D-28054 Bremen

Münchener Str. 77, D-28215 Bremen

Tel. 0049 (0) 421 35 03 - 0, Fax 0049 (0) 421 35 03-393

E-mail [gestra.ag@flowserve.com](mailto:gestra.ag@flowserve.com), Web [www.gestra.de](http://www.gestra.de)

